

REVISIONS				
ZONE	REV.	DESCRIPTION	DATE	APPROVED
--				

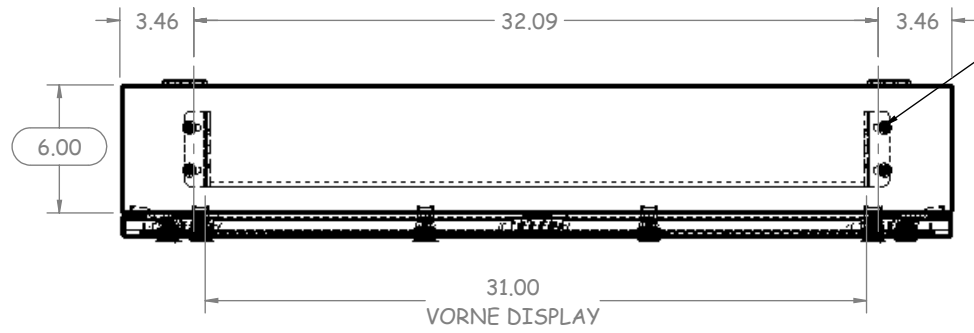

TOP & BOTTOM BRKTS
INTALLED WITH 1/4-20 X .500
CD STUDS-(4X)

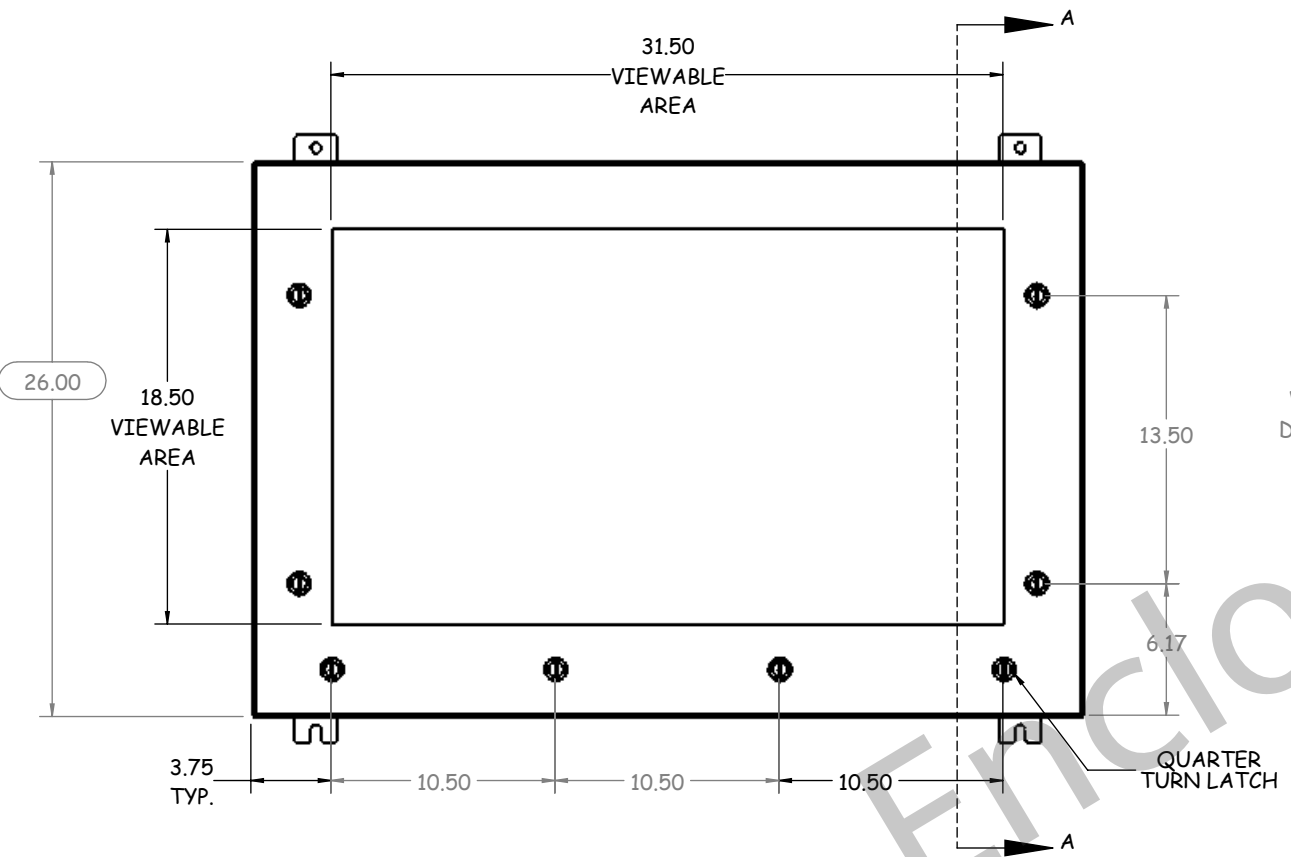

3/8-16 X .75" S/S HEX TAP BOLT
WITH 3/8-16 S/S HEX NUT
3/8 FLAT WASHER S/S AND
3/8 LOCK WASHER S/S (TYP. 2X)

12ga. 316SS
MOUNTING BKTS

QUARTER
TURN LATCH

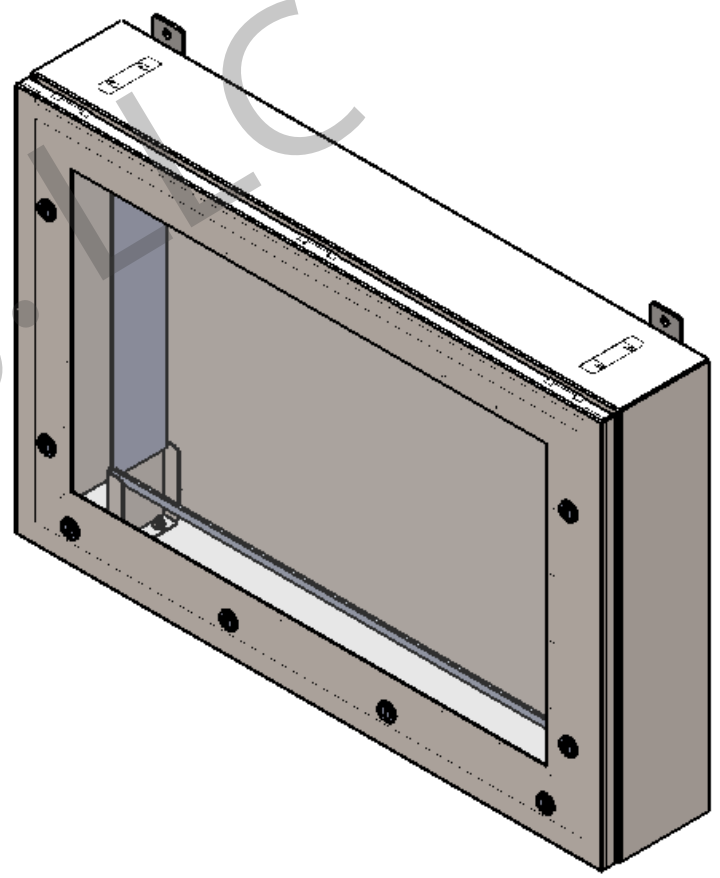

SECTION A-A
SCALE 1 : 9

NOTE

- NEMA 4X RATED / UL LISTED / IP66, CSD STYLE ENCLOSURE
- 14GA. 316 STAINLESS STEEL CONSTRUCTION, BRUSH FINISHED.
- NO BACKPANEL, OR STUDS.
- QUARTER TURN LATCH / CONCEALED HINGE.
- 1/4" LEXAN WINDOW WITH 10-32 CD STUDS INSIDE ATTACHED.

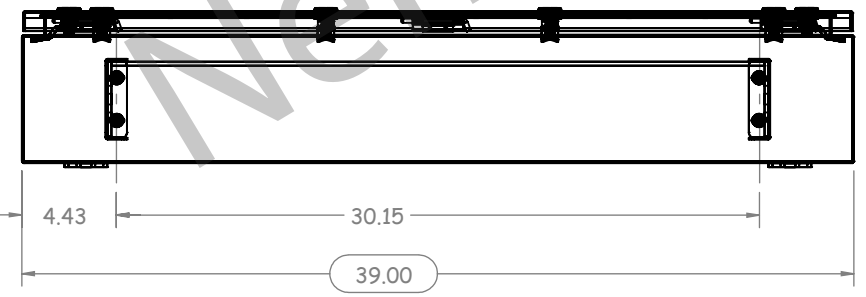

**Fits Vorne Productivity Unit:
XL600-4T (not included)**



PROPRIETARY AND CONFIDENTIAL
THE INFORMATION CONTAINED IN THIS
DRAWING IS THE SOLE PROPERTY OF
NEMA ENCLOSURES. ANY
REPRODUCTION IN PART OR AS A WHOLE
WITHOUT THE WRITTEN PERMISSION OF
NEMA ENCLOSURES IS
PROHIBITED.

UNLESS OTHERWISE SPECIFIED:
DIMENSIONS ARE IN INCHES
TOLERANCES:
FRACTIONAL: ±1/16
ANGULAR: MACH ±1°
HOLE +.004/-001 (LASER ONLY)
ONE PLACE DECIMAL ±.0625
TWO PLACE DECIMAL ±.030
THREE PLACE DECIMAL ±.015
POWDER COAT STANDARD 2 MIL ±.5 MIL

	NAME	DATE
DRAWN	OD	11/30/16
CHECKED		
ENG APPR.		
MFG APPR.		
Q.A.		
MATERIAL	AS NOTED	
FINISH	AS NOTED	
DO NOT SCALE DRAWING		



TITLE:
NEMA ENCLOSURES
26.00"H X 39.00"W X 6.00"D
NEMA 4X/ IP66
20.2" X 31" X 3.5" VORNE DISPLAY

DWG. NO. CHDSS6263906VD REV

SCALE: 1:8 WEIGHT: SHEET 1 OF 2

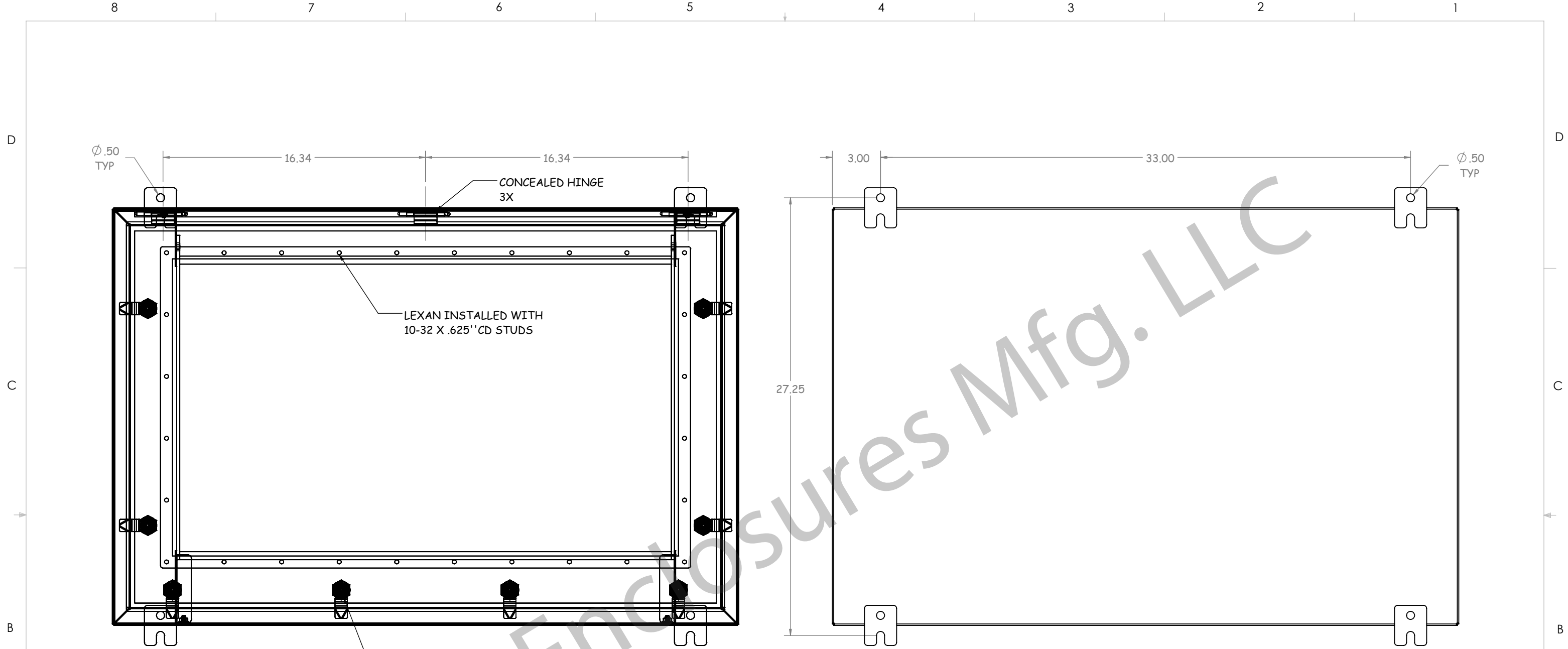

1/4-TURN LATCH

CONCEALED HINGE
3X

LEXAN INSTALLED WITH
10-32 X .625" CD STUDS

DESIGNABOX™



PROPRIETARY AND CONFIDENTIAL
THE INFORMATION CONTAINED IN THIS DRAWING IS THE SOLE PROPERTY OF NEMA ENCLOSURES. ANY REPRODUCTION IN PART OR AS A WHOLE WITHOUT THE WRITTEN PERMISSION OF NEMA ENCLOSURES IS PROHIBITED.

UNLESS OTHERWISE SPECIFIED:
DIMENSIONS ARE IN INCHES
TOLERANCES:
FRACTIONAL: ±1/16
ANGULAR: MACH ±1°
HOLE: +.004/-0.001 (LASER ONLY)
ONE PLACE DECIMAL: ±.0625
TWO PLACE DECIMAL: ±.030
THREE PLACE DECIMAL: ±.015
POWDER COAT STANDARD 2 MIL ±.5 MIL

	NAME	DATE
DRAWN	OD	11/30/16
CHECKED		
ENG APPR.		
MFG APPR.		
Q.A.		
MATERIAL	AS NOTED	
FINISH	AS NOTED	
DO NOT SCALE DRAWING		



DESIGNABOX™	
TITLE: NEMA ENCLOSURES 26.00"H X 39.00"W X 6.00"D NEMA 4X/ IP66 20.2" X 31" X 3.5" VORNE DISPLAY	
DWG. NO. CHDSS6263906VD	REV
SCALE: 1:8	WEIGHT:
SHEET 2 OF 2	